

THE SCOUT™ POOL LIFT

US PATENT NO. D507,769 S

FLIP-UP
ARMRESTS

SAFETY
BELT

FOOTREST

FIXING
ANCHOR

Ø 1.9" X 6" POST

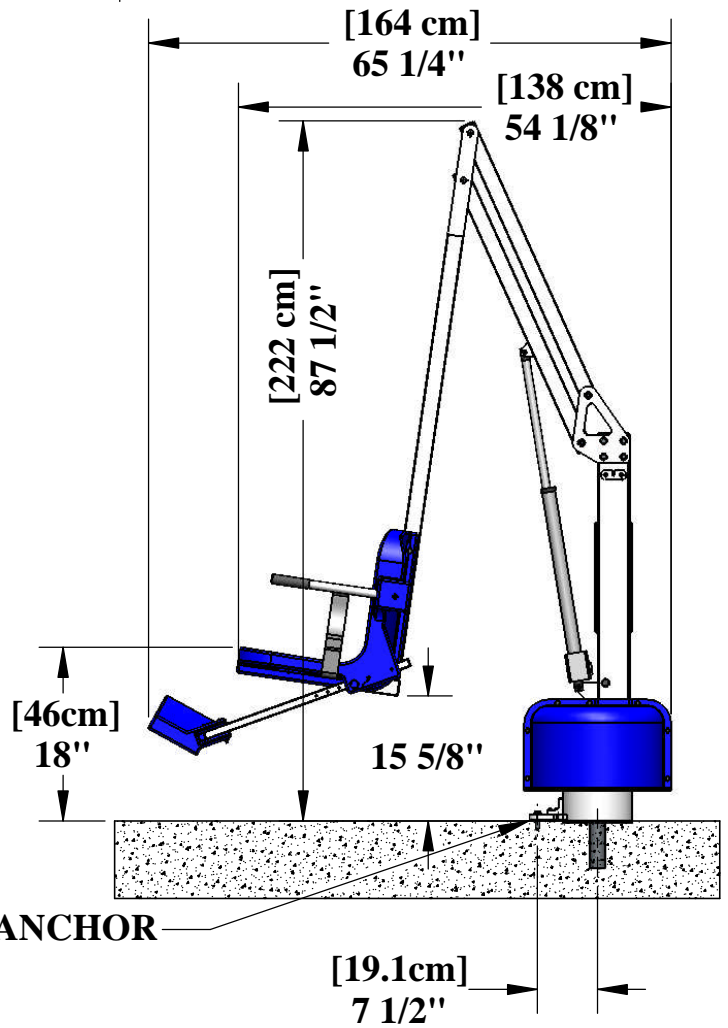
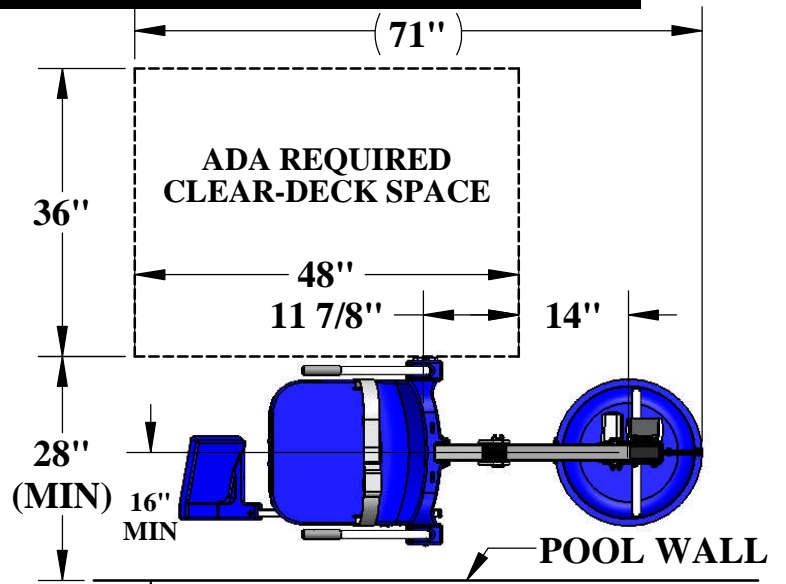

Inspected And Verified To Meet
Applicable Sections of ADA
Guidelines Section 1009.2 By

wyle
laboratories

A Registered ISO 9001
Laboratory

9889 GARRYMORE LANE
MISSOULA, MT 59808
(406) 549-0769
FAX (406) 549-2602

NOTE:
*SPECIFICATIONS ARE SUBJECT TO CHANGE WITHOUT NOTICE

PRODUCT:	F-800SC-DER-D	
DWG #:	F-800SC-DER-D-1	
SCALE:	1:24	DATE: 3/4/13
DRAWN BY:	DS	REVISION: F

Aqua Creek Products
The Total Solution for Pool and Spa Access

THE SCOUT™ POOL LIFT

US PATENT NO. D507,769 S

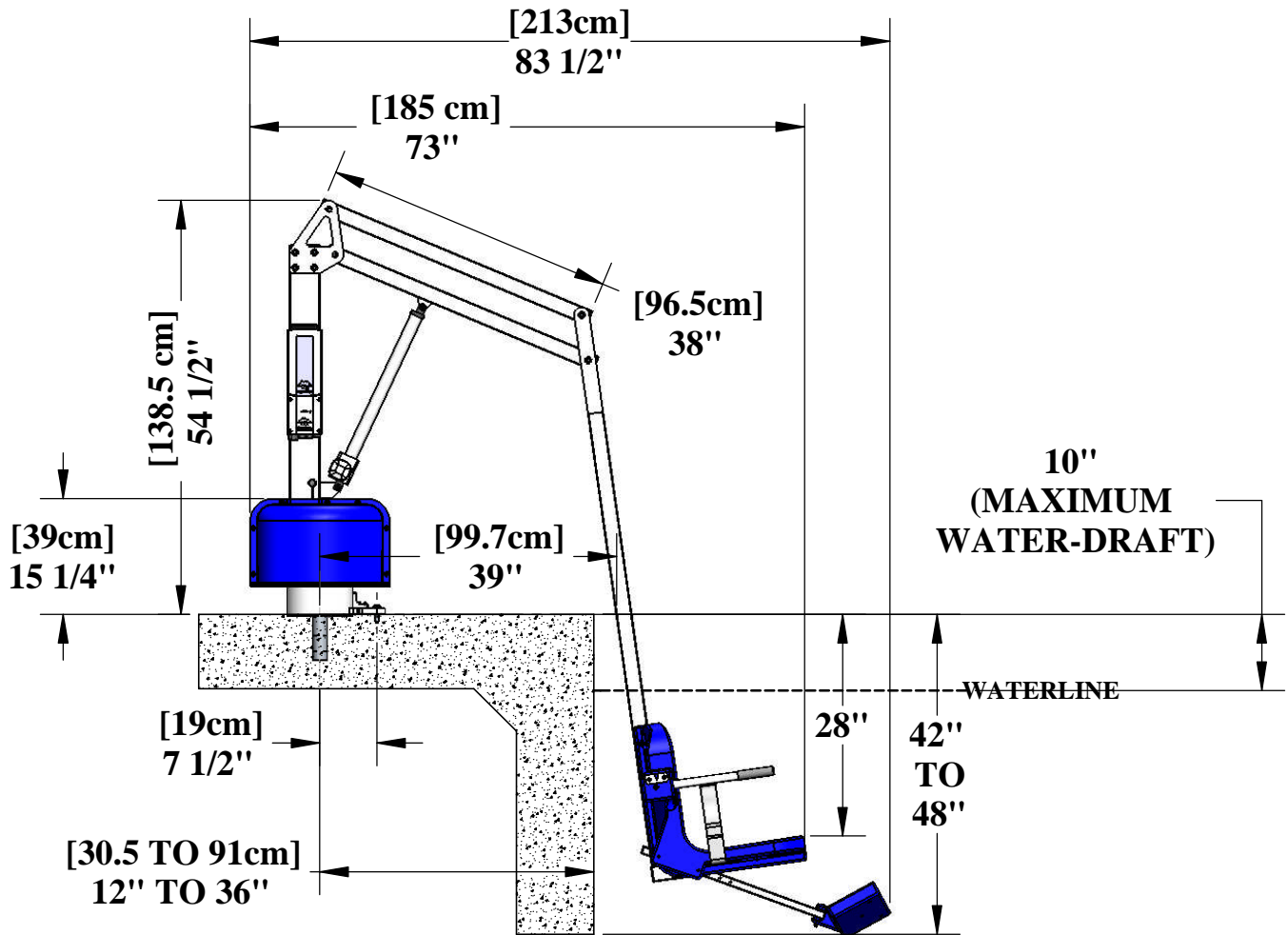
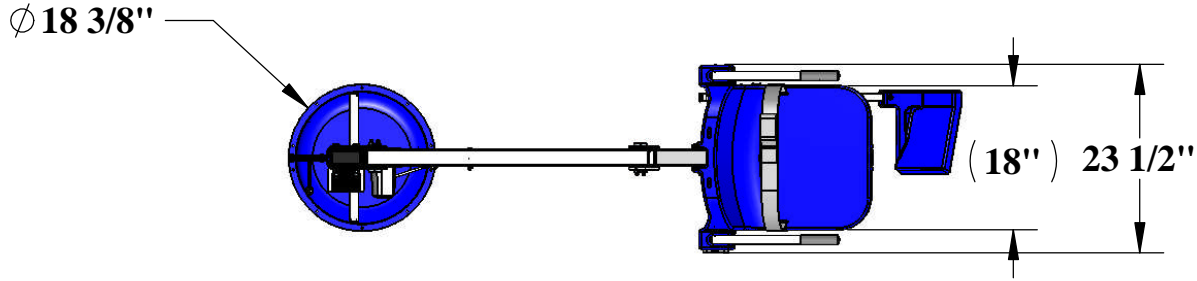

Aqua Creek Products
The Total Solution for Pool and Spa Access

9889 GARRYMORE LANE
MISSOULA, MT 59808
(406) 549-0769
FAX (406) 549-2602

NOTE:
*SPECIFICATIONS ARE SUBJECT TO CHANGE WITHOUT NOTICE

PRODUCT:	F-800SC-DER-D	
DWG #:	F-800SC-DER-D-2	
SCALE:	1:24	DATE: 3/4/13
DRAWN BY:	DS	REVISION: F

THE SCOUT™ POOL LIFT

US PATENT NO. D507,769 S

SPECIFICATIONS:

***LIFTING CAPACITY: 350lbs [159kg]**
STATIC LOAD CAPACITY: 525 lbs [238kg]

MAXIMUM WATER DRAFT (DECK TO WATER): 10" [25.4cm]
MAXIMUM SETBACK: 36" [91cm]

WEIGHT: 175 lbs [79 kg]

MATERIALS:

BASE: TYPE 304 STAINLESS STEEL, PVC, CONCRETE, RUBBER
MAST & ARMS: TYPE 304 STAINLESS STEEL
CHAIR & FOOTREST: LOW-DENSITY POLYETHYLENE
SAFETY BELT: HEAVY-DUTY POLYESTER STRAP, HOOK & LOOK FASTENER
POWDER COATING: EPOXY, APPLIANCE WHITE
FIXING ANCHOR-TAB: HIGH-DENSITY POLYETHYLENE
FIXING BOLT: ϕ 1/2"-13 X 2", 316 SS

STANDARD EQUIPMENT:

DUAL FLIP-UP ARMRESTS
FLIP-UP FOOTREST
18" WIDE CHAIR

24V BATTERY & CHARGER
WATERPROOF HANDSET/REMOTE
SAFETY BELT

AVAILABLE OPTIONS:

ϕ 1.9" ID X 6" BRONZE ANCHOR, SCOUT
HEADREST ASSEMBLY
PULLOUT LEGREST
COVER (NON-LOCKABLE)
COVER (LOCKABLE)
TRANSPORT CART

PART NUMBER

F-808SA
F-722HRR
F-105LAR
F-450SC
F-450SC-AC
F-814SCTC

ANCHOR ADAPTERS:

"SPLASH"	(2-1/2" SQUARE)	F-820
"LIFEGUARD"	(2-1/2" ID)	F-822
"ELKHORN"	(2-3/8" ID)	F-824
"HOYER"	(2-5/8" ID)	F-826

***NOTE: LIFTING CAPACITY IS 300lbs [136kg] WITH ANCHOR ADAPTERS**



The Total Solution for Pool and Spa Access

9889 GARRYMORE LANE
MISSOULA, MT 59808
(406) 549-0769
FAX (406) 549-2602

NOTE:
*SPECIFICATIONS ARE SUBJECT TO CHANGE WITHOUT NOTICE

PRODUCT:	F-800SC-DER-D		
DWG #:	F-800SC-DER-D-3		
SCALE:	1:1	DATE:	3/4/13
DRAWN BY:	DS	REVISION:	F